



## **HFS21 Underwater Housing**

*Setup, Use, and Care Guide*

Copyright 2010, Gates Underwater Products, Inc.

Last document revision: May 2010

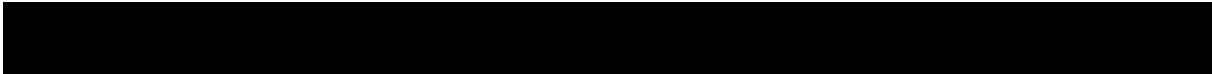

Product photos by Lee Petersen.

This manual and current revision is available in 8.5 x 11 size and full color at

<http://www.gateshousings.com/documentation.html>



***Gates Underwater Products, Inc.***

13685 Stowe Drive  
Poway, California 92064 USA

Phone: 800.875.1052 toll-free in the U.S.

858.391.0052 outside the U.S.

Fax: 858.391.0053

Web: [GatesHousings.com](http://GatesHousings.com)

## Table of Contents

---

	Setup, Use, and Care Guide.....	1
1:	Introducing the HF-S21.....	4
	Features.....	4
	Warranty Disclaimer .....	4
	Unpacking the HFS-21 .....	5
2:	Cautions.....	6
3:	The HFS-21 Setup.....	7
	HFS-21 Housing Preparation.....	7
	Camera Preparation .....	8
	Installing the Camera into the Housing .....	9
	Installing Remote into Housing .....	10
	Closing the housing .....	11
	Handle Installation .....	12
	Remote Button Arm Installation .....	13
	Water Alarm (Optional).....	14
	Seal Check (Optional).....	15
	Video Out (Optional) .....	15
	Microphone (Optional) .....	15
	Final Checks .....	15
4:	HFS-21 Operation.....	16
	Right Side Controls.....	17
	Top Controls .....	17
	Rear Controls.....	17
	Left Side Controls .....	18
	Front Controls .....	18
	Remote Control.....	19
	Changing Filters.....	20
	Changing Ports.....	21
	Using the GP32 Wide Angle Port .....	22
	Cleaning Ports and Filters .....	22
	Diopters .....	23
	Tips for Shooting Video with the HF-S21 .....	24
	Lighting Systems .....	25
	Housing Care and Maintenance .....	25
	O-Ring Care and Maintenance .....	25
5:	Customer Support.....	26

# 1: Introducing the HF-S21

---

Congratulations on owning a new Gates product: the HFS-21 housing. You've selected a product that will provide years of value and reliable service. We designed the HFS-21 specifically for the Canon HF-S21, HF-S20 and HF-S200 digital video cameras.

Please read through this entire guide to learn about the housing so you can get the most out of this imaging tool. In this section, we'll introduce you to the features of the HFS-21 so you can get started.

## ***Features***

The HFS-21 has several key features:

- **Small and Travel-friendly.** At just a few pounds the HFS-21 packs easily into your luggage or dive gear.
- **'Bulletproof' construction.** Gates legendary reliability is inherent in the HFS-21: machined aluminum shell, stainless hardware and reliable mechanical controls.
- **Precision optics.** The HFS-21 allows the use of a variety of ports including Wide and Macro.

## ***Warranty Disclaimer***

The HFS-21 is a tool that, like any tool, requires knowledge and understanding to be effective.

Your responsibility is to learn the proper setup, use and care of the HFS-21. Because we can only provide you with the information necessary to do so, Gates does not warrant the contents of your housing (e.g. your camera and lenses) under any circumstance. For the same reasons, Gates does not warrant optical performance or image quality.

We warrant the HFS-21 as an image acquisition tool for a period of 2 years. The optional Seal Check unit is warranted for 1 year. Optics are warranted for a period of 1 year or 100 hours water contact, whichever comes first.

If you have any questions about the setup, use and care of the HFS-21, contact Gates directly. Details are in section 5.

## ***Unpacking the HFS-21***

After you remove the HFS-21 from its shipping container, carefully inspect it for missing parts or damage that may have occurred during shipment. If you discover any discrepancies, contact Gates or your dealer immediately for assistance.

### ***Standard Parts***

The HFS-21 comes with the following standard items:

- The HFS-21 Housing**
- The HFS-21 Camera Dovetail (to which the HFS20/21/200 cameras mount)**
- Various assembly and spare parts for the HFS-21 including mounting screws, o-rings and lubricant.**
- Port(s) of choice (Dome, Flat, Wide Angle, etc)**
- Handle Mount (which may already be affixed to the housing)**
- Remote Button Arm including mount and set screws.**

### ***Optional Parts***

Your housing may also come with optional items:

- Microphone**
- Water Alarm**
- Light System (user install)**
- Seal Check**
- Video Out**

## 2: Cautions

---

- ▶ **TRANSPORT.** NEVER ship or transport your HFS20/21/200 camera inside the housing. The housing was not designed for this purpose and severe damage may result.
  
- ▶ **USER RESPONSIBILITY.** This Setup, Use and Care guide contains important detailed procedures for setup and use of the HFS-21. It is the user's responsibility to read, understand and employ these procedures. Failure to do so can result in poor or non-operation of the HFS-21 and may void your warranty.

Contact Gates if you have questions about this manual or using the HFS-21.

## 3: The HFS-21 Setup

The HFS-21 housing requires complete and thorough setup prior to use.

### *HFS-21 Housing Preparation*

- **Open the HFS-21 shell.** Two stainless steel safety latches secure the housing halves. They have a positive locking feature, so to open them you must first depress the center bar release while lifting the rear lever.
- **Separate** the rear half of housing from the front.
- **Remove the camera dovetail mount (CDM).** Rotate the lock counterclockwise and slide the mount to the rear.
- **Retract and Rotate controls.** Pull out the Manual Dial, Manual Button Select Dial and Zoom ~ 1 inch or until they stop.

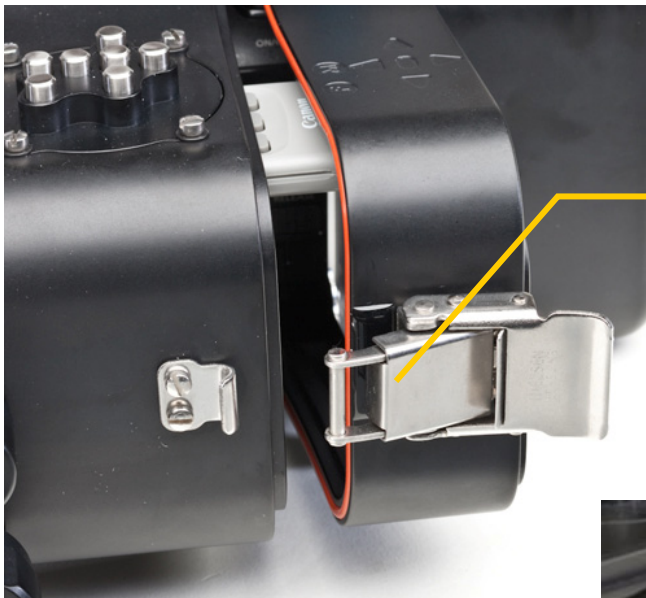

Release the latches and separate the housing shell halves.

Rotate the lock to this position and slide the CDM out of the housing.

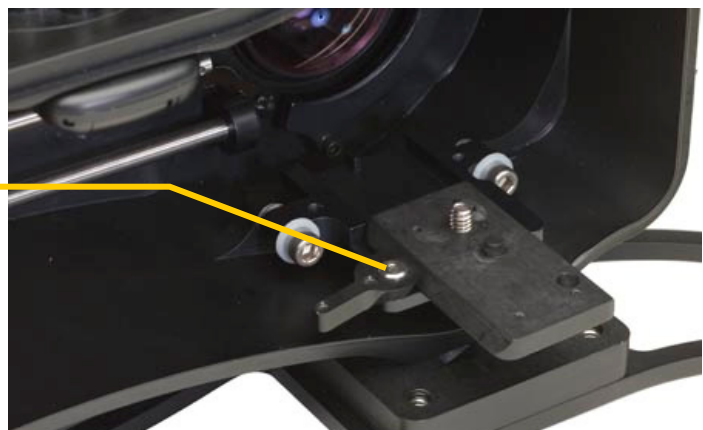

## Camera Preparation

Your CANON camera will need some preparation before installing into the housing.

- ❑ **Remove any lens caps or external lenses** you may have added to the front of the camera.
- ❑ **Install** a charged battery.
- ❑ **Tighten the hand strap** to its shortest position and tuck the 'tail' back into the hand strap.
- ▶ **CAUTION:** Failure to perform this step may result in the hand strap becoming caught in the housing seal and accidental flooding.
- ❑ **Install the camera onto the CDM** using one of the short 1/4-20 flat head screws by threading into the tripod mount found on the bottom of the camera. A screwdriver or coin may be used to tighten snug, but do not over tighten.

Remove any lens caps or filters.

Tighten the handstrap to its shortest position.

Install the CDM as shown. Tighten the 1/4-20 screw gently and snug.



## Installing the Camera into the Housing

- ❑ **Carefully slide camera on its CDM** into the front housing half. The CDM will mate and slide into the mating mount on the housing.
- ❑ **Observe** that the camera mates into the alignment collar at the front of the shell, just behind the port opening.
- ❑ **Secure the camera** by rotating the lock clockwise until snug.
- ❑ **Press in controls.** When the camera is installed into the front housing half, press in the Manual Button and Manual Dial controls to mate with the camera.
- ❑ **Check controls.** At this point it's a good idea to check all controls on the front shell for proper operation. (See section 4 for controls mentioned here.)
- ❑ **Open the LCD fully.**

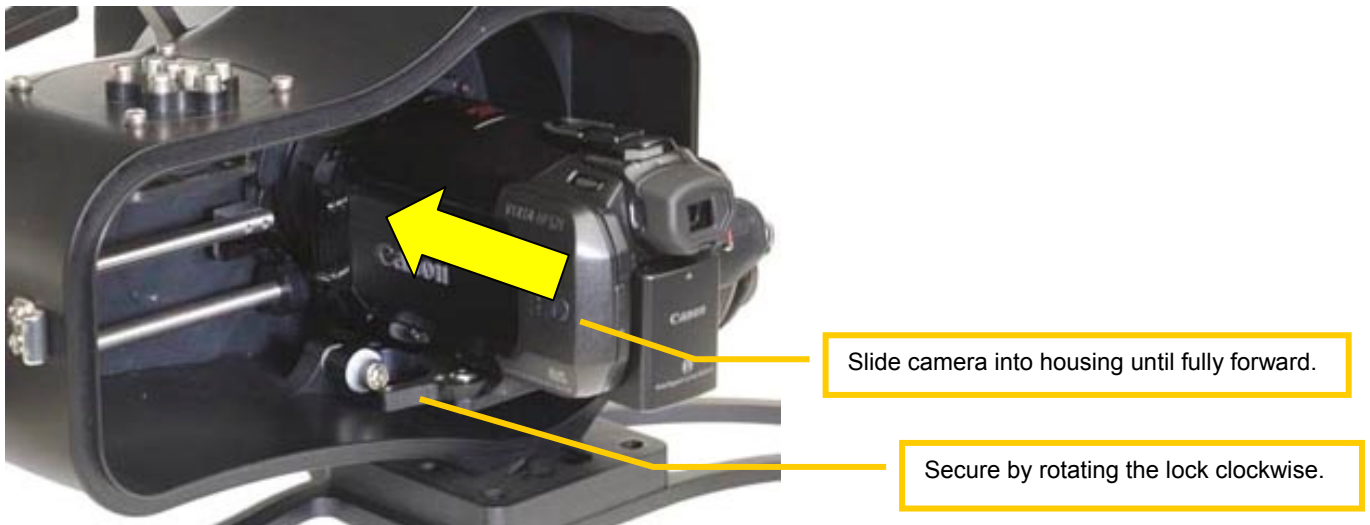

Open the LCD fully and make sure Remote is pushed in all the way.

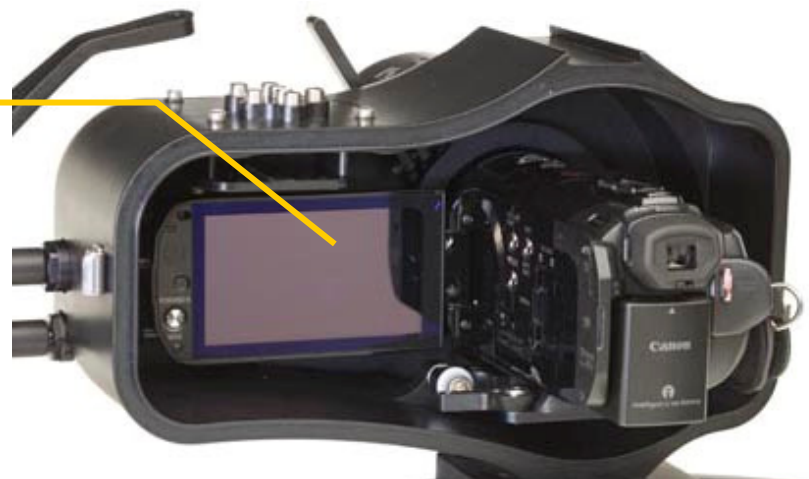

## ***Installing Remote into Housing***

- **Carefully slide the remote onto rails with the top end first until it stops.**



## Closing the Housing

- **Carefully inspect** o-ring on back half and the sealing surface on front half. Make sure they are clean and in good condition.
- **Place back half onto the front housing half.** You will clearly see when the housing halves align and seat together properly.
- **Locate and close** the two latches at the same time.
- ▶ **CAUTION:** The safety latches must be closed and locked prior to use to avoid opening underwater. It is your responsibility to make sure the latches are secure, locked, and in good condition. **DO NOT** enter the water with a faulty latch. Gates will replace a damaged or faulty latch free of charge.
- **Carefully inspect the parting line** between front and rear housing. If this line is not even all the way around, remove the back and determine the reason. (O-ring out of place, hand strap interference, etc.) **Failure To Do This May Result In A Wet Camera!**
- **Press controls in until they touch camera buttons.** Note positioning of each control as it touches the camera button/switch it is designed to actuate. (See Section 4)
- **Power up the camera.** Check all controls for the proper operation before entering water. (See section 4)
- **Check the Port.** It should be seated flush on the front bulkhead with no uneven gaps. If the port is not seated properly, remove the port and re-install per directions in a subsequent section of this document. Also check that the dot or indent on the port is aligned with the dot on the housing.

Mate the shells and close the two latches. The shells should mate without obstruction.

Once closed, check the parting line for gaps.

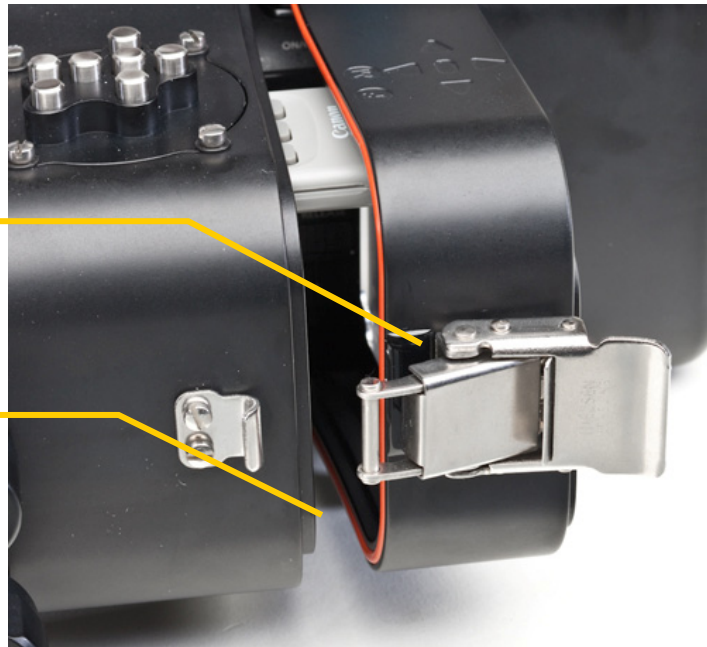

## Handle Installation

- ❑ **Remove the knurled retainer** from the handles, then place the handles just behind the dovetail found on the bottom of the housing (see photo).
- ❑ **Slide the handles onto the housing dovetail.** It may take firm pressure to fully seat the handles until they come to a solid stop.
- ❑ **Attach the knurled retainer** to secure the handles onto the housing.

Position the handles behind the dovetail, then slide the handle forward onto the housing until it stops.



## Remote Button Arm Installation

The Remote Button Arm can be installed to aid actuation of the remote push buttons. It provides a firm handle grasp closer to the buttons. The arm is a standard part included with your housing, but not installed.

- **Locate Button Arm** onto the top left handle with bend facing up and toward the remote buttons.
- **Position the arm** in the position you desire, then tighten the mount screw with the 5/32 allen tool.
- **Secure the arm in position** by tightening the set screw using the 3/32 allen tool. Tighten only enough to secure the arm, but do not overtighten.

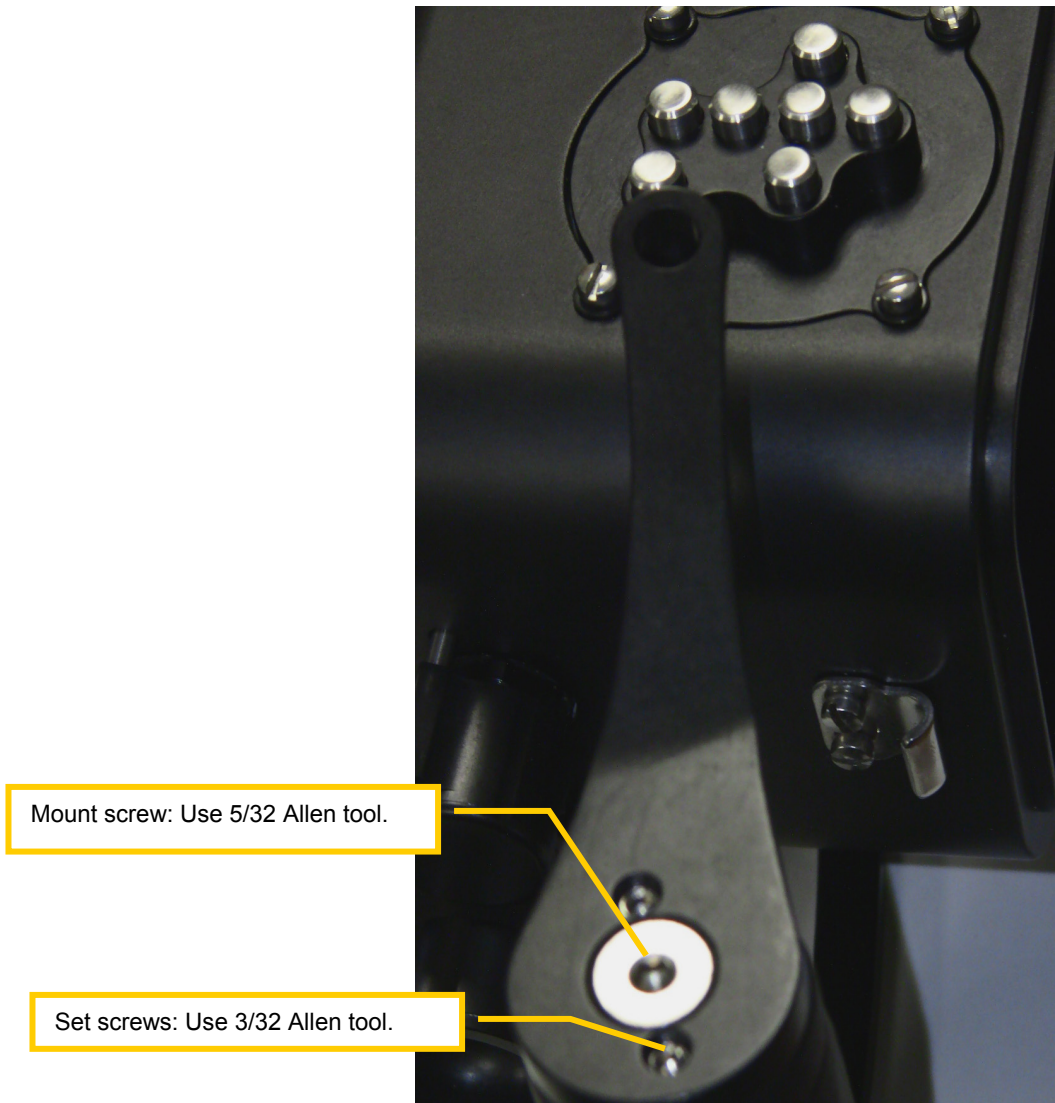

## Water Alarm (Optional)

If you have the optional water alarm installed there are three alarm conditions to know:

<b>Condition</b>	<b>LED</b>	<b>Siren</b>
New Battery (Insertion)	Bright Intense blink while siren plays	Ascending tones played 4 times
Water Intrusion	Bright Intense Blink	Grating Warble sound. Alarm will sound for duration of detection.
Low Battery	Low Intensity fast blink	Descending tones played 8 times pausing approx. 20 seconds between plays after alarm test or water detection.

The alarm can be tested anytime by shorting the detection contacts that lead to the water alarm transducer. The water detection condition will activate for 6 seconds. If the battery is drained the low battery condition will sound.

The water alarm requires a single 6V battery like Radio Shack model 23-469 or A544.

Your battery should be removed when stored (e.g. between dive trips). Check the battery prior to every dive to ensure proper operation. Change when indicated.

- ▶ **CAUTION:** You must wait a minimum of 30 seconds between battery insertions to allow the unit to fully discharge.



Typical Water Alarm installation.

## ***Seal Check (Optional)***

- **Seal Check Manual.** Follow the procedures in the Seal Check manual for verifying integrity of the housing and monitor.
- ▶ **NOTE.** Pulling a vacuum on the HFS-21 will take only a few seconds. Be careful to avoid excessive vacuum greater than 8 in Hg.

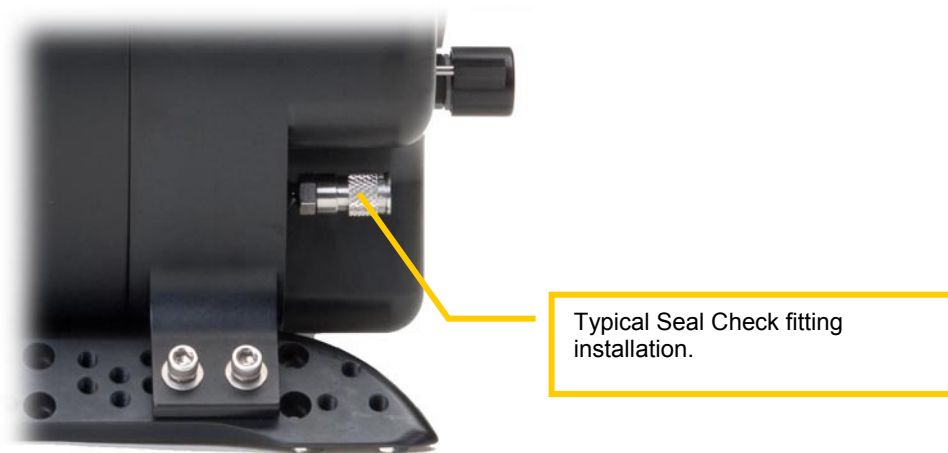

## ***Video Out (Optional)***

- **Camera connection.** If you have the video out installed, plug the video connector into the camera after inserting the camera into the housing.

## ***Microphone (Optional)***

- **Camera connection.** If you have the Submersible Microphone installed, plug the audio connector into the camera just prior to inserting the camera into the housing.

## ***Final Checks***

- **Visual Inspection.** Look closely at all seal mates – Port and Main Housing seal – for gaps. Look over the housing one final time.
- **Verify operation.** As a final check, power on the camera and verify all controls are functioning normally.

---

## 4: HFS-21 Operation

---

Your Gates housing utilizes 100% mechanical controls to provide you with the most reliable operation possible. They either rotate and/or depress to provide smooth and consistent operation. (see 'Housing Care and Maintenance' section).

The housing controls are designed by Gates engineers, to the extent possible, to feel and behave like the camera controls. With time and use, the housing controls will become quite familiar and easy to use.

To help familiarize you with the housing controls, Gates recommends reviewing each control individually, how it actuates the corresponding camera control, and operating it to get a 'feel' for the control. You can view all front housing controls with the housing open. After reviewing all controls, perform a 'simulated' dive by operating the controls as you would in the water.

One final note about controls: when operating any control out of water, you may need to press the control against the housing, into the position it would naturally find while under water pressure. The controls are designed to operate properly in this position.

## Right Side Controls

- **Record / Standby.** The Record/Standby control is red and operates with a momentary clockwise rotation.
- **Photo.** This control operates similarly with a clockwise rotation. Press and hold long enough for the camera to focus and capture a photo.

## Top Controls

- **Mode.** The Mode button operates by pressing down and rotating.
- **Zoom.** The Zoom control is blue and operates with a momentary rotation.
- ▶ **TIP:** The Zoom control operates free and smooth when well lubricated. This should be done after storage and often during heavy use (as much as every 2 or 3 dives).

To lubricate, pull up the control to expose a portion of the control shaft, and lightly apply silicone. Push the control back in and rotate both directions until it operates freely.

## Rear Controls

- **Power.** The Power button operates by with a momentary clockwise rotation.

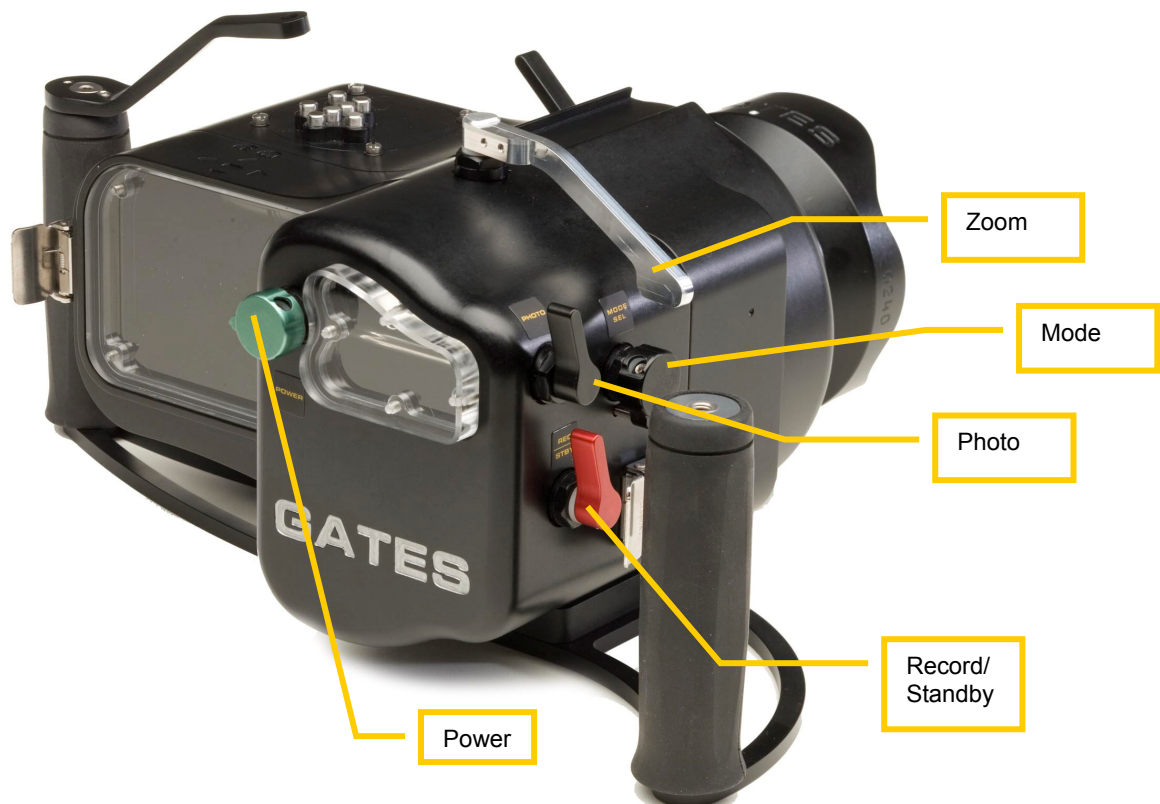

## Left Side Controls

- **Manual Button.** The Manual Button accesses the manual functions like focus and exposure.
- **Manual Dial.** After actuating the Manual Button, this control rotates the Manual Dial to vary the selected function like focus or exposure.

## Front Controls

- **Flip Filter.** The Flip Filter moves the color correction filter in/out of position of the camera view.



## ***Remote Control***

The remote is used to give full menu access and access the white balance control. Each button requires a simple push to operate.

- **White Balance/Tele Macro.** Refer to the HF-S21/20/200 camera user manual for the specific sequence to access these functions.



## Changing Filters

The color correction filter in your housing may be changed to accommodate different gradient filters. “Blue water” and “green water” are the two most common, recognizable by their orange and purple color, respectively.

- **Removal.** The color filter is held in place by a tension screw in the filter holder. Loosen this screw with a 7/64 Allen tool.
- **Installation.** Rest the filter in the holder and tighten with a 7/64 Allen tool. **Tighten just enough to secure the filter. Do not over tighten.**
- **Cleaning.** You will likely have fingerprints on the filter after installing, so clean the filter according to the directions in the “Cleaning Ports and Filters” section.

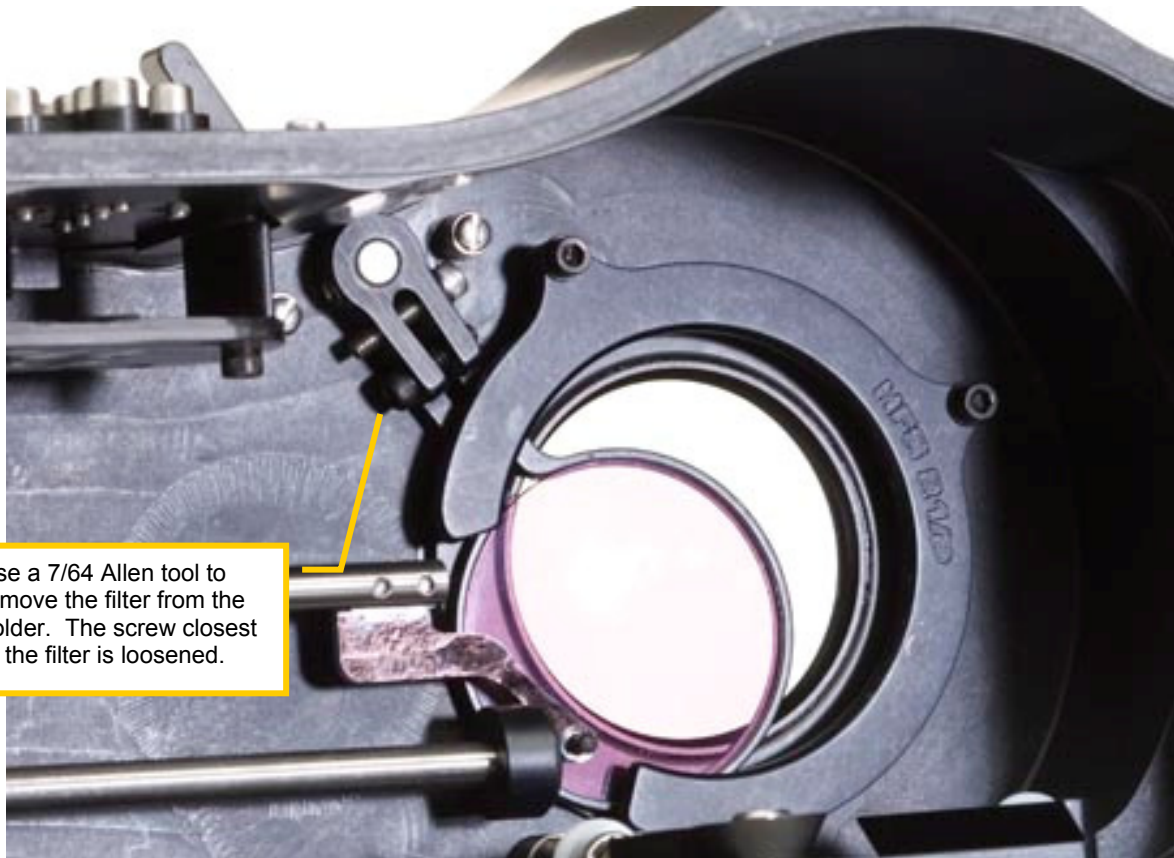

## Changing Ports

Gates offers several ports for your HFS-21 housing, which attach with a bayonet-style mount. Port changes are easy and straightforward:

- **Removal.** You will see alignment dots on the housing and on the port. When aligned, the port is fully engaged and ready for underwater use. Turning the port 90 degrees, or  $\frac{1}{4}$  turn in either direction to face the dot left or right allows the port to release from the front of the housing. Gently pull the port directly away from the housing to do so.
  - **Inspect the o-ring** -- Before installing a new port, perform an inspection and lubrication of the sealing o-ring. See “O-ring Care and Maintenance” in this Use and Care Guide for specific details.
  - **Installation.** Mounting a different port is directly the opposite: Insert the port into the front bulkhead of the housing with the alignment dot on the port facing left or right, or  $\frac{1}{4}$  turn away from the dot on the top of the housing. You may need to gently push the port into the bulkhead to fully seat the port. Then turn the port until the dot on the port aligns with the dot on the housing. Be sure the port is fully seated and flush with the housing. You should see no gaps between the port and the housing.
- ▶ **CAUTION:** The Port must be fully seated and flush with the housing to avoid flooding.

Align dot on port and housing.



## Using the GP32 Wide Angle Port

- **Super Range image stabilization.** With the HF-S21 camera only, you may find momentary vignetting occurs with swift movements left or right when using Super Range image stabilization. If so, make smooth pans to either side, or change the image stabilization to Standard mode.
- **Photo Mode.** Due to variations in cameras you may find very slight vignetting in Photo Mode and at highest picture size (L 3264 x 2456). To avoid this, it may be necessary to zoom ~ 2% from full wide. One momentary action on the zoom control toward telephoto is sufficient.

## Cleaning Ports and Filters

Gates ports can be cleaned readily by following these simple guidelines.

- **Dust or Lint** can be blown with compressed air, preferably from a can. Do not clean the surfaces if it is unnecessary.
- **Salt deposits or sand may also be removed with compressed air.** Use a soft lens brush if necessary to brush away foreign material that remains.
- **Rinse fresh water over the outside of the port, if necessary,** to loosen any residual salt or sand that may remain. Do this with the port sealed on your housing to keep water away from the rear of the port.
- ▶ **CAUTION:** Do not submerge the GP32 wide angle port in water when separated from the housing! This port is not sealed from the backside and damage will result if submerged.
- Only if necessary, **clean the port using a mild cleaning solution and a non-abrasive, lint free cloth.** Use light circular strokes when wiping away cleaning solution and any foreign material. Excessive pressure used when cleaning dirty lenses (e.g., rubbing sand into the lens surfaces) may damage coatings. Use a light touch.
- ▶ **CAUTION:** Not all cloths are lint free and non-abrasive! Use of an abrasive material (such as cotton balls and cotton fabric) may scratch the glass and/or coating of Gates ports and will void the warranty.
- ▶ **TIP:** Gates offers approved cleaning solutions and lint free cloths as accessory items. Use of these materials will not void your warranty.

## ***Diopters***

Diopters may be used with the HFS-21 housing and the FP32 Flat Port for close up/macro imaging. There is sufficient space between the camera and port to utilize up to three diopters stacked on the camera. The camera utilizes diopters in a 58mm holder.

- ▶ **NOTE** the Filter cannot be used with diopters. When installing the camera with diopters ensure the filter is positioned as far as possible away from the port opening.



## ***Tips for Shooting Video with the HF-S21***

- **Zoom.** Zoom shots can be used for good effect, such as ranging telephoto to wide to highlight critter camouflage. Smooth, steady zoom is generally best for such shots, and is achieved by setting your camera zoom slider to do so. In the camera menu are four settings: Variable and Speeds 1 through 3. Variable will, as the name suggests, zoom slow to fast depending on how far you move the zoom slider, and is difficult to control for that smooth, steady zoom. Speed 2 or 3 is recommended, and provides a constant zoom rate regardless of the zoom slider position.
- **Manual Focus.** The HF-S21 housing allows direct access to the Manual Dial and Manual Button on the camera. These buttons can have a variety of functions assigned to them, but a common and useful function underwater is manual focus. With this setting you can prevent the camera from auto 'hunting' or 'seeking' to find focus.

A common technique is allowing the camera to auto focus on your subject (or on something about the same distance from you as your subject), then switch to manual focus. This 'freezes' the focus at that distance – no hunting or seeking. The GP32 wide angle port further provides a large depth of field (DOF), so most everything in front of your camera will be in focus, too.

- **Image Stabilization.** The Canon HF-S21/S20/S200 cameras have built-in image stabilization functions. These are useful underwater for steady, even shots, so you should have image stabilization turned on.

One note, however, is the HF-S21 camera, which has Super Range image stabilization. This new technology can be quite forgiving to shaky hands; however it does so at the expense of playing 'catch up' to your subject. That is, if you move the camera left to right you may notice the image 'catches up' and keeps moving even though you've stopped moving the camera.

This technology can also have an adverse effect in the form of vignetting. With the GP32 port in particular, you may see momentary black corners with sharp movement of the camera. To avoid this, set the HF-S21 camera into Standard image stabilization mode. This mode works well and avoids any potential for 'catch up' or vignetting.

- **GP32 Wide Angle Port.** In photo mode you may find very slight darkening of the corners – vignetting – in the highest resolution (L 3264 x 2456). Variations in cameras may reveal different degrees of vignetting (or none at all), and this **only occurs in photo mode**. To avoid this, zoom ~ 2% from full wide. One momentary action on the zoom control toward telephoto is sufficient to get past any vignetting.

## ***Lighting Systems***

Your housing comes ready to accept different lighting systems depending on your requirements. If you purchased lighting systems from Gates you will find a separate document to guide you through installation to your Gates HFS-21 housing.

## ***Housing Care and Maintenance***

Proper care of your Gates housing is important to provide you reliable operation and long life. You'll find all the guidelines in the "Housing Care and Maintenance" document included with your Gates housing. You can also find it on Gates web site at [www.GatesHousings.com](http://www.GatesHousings.com).

## ***O-Ring Care and Maintenance***

Your Gates housing has 2 serviceable o-rings. One is located between the mating halves of the housing (the large orange one), and one is located on the Port.

Servicing the o-rings is easy and covered in the "Housing Care and Maintenance" document in this package. It can also be found on the Gates website at [www.gateshousings.com](http://www.gateshousings.com).

- ▶ **CAUTION: Do not lubricate the large orange o-ring! It is a special silicone o-ring and can be damaged by petroleum-based lubricants.**
  
- ▶ **CAUTION: Never use metal tools or objects for removing o-rings!**

## 5: Customer Support

---

Should you have any questions about the HFS-21 and its operation, please contact Gates at the numbers below.

Email: [Customer.srvc@GatesHousings.com](mailto:Customer.srvc@GatesHousings.com)

Web: [www.GatesHousings.com](http://www.GatesHousings.com)

Phone: 858.391.0052

Fax: 858.391.0053