



Setup, Use and Care Guide

FX1/Z1 Housing

Dear Gates Customer,

Welcome to the Gates family! You now own one of the finest underwater housings available, and we thank you for choosing Gates. For over 36 years Gates has crafted the most **reliable**, **durable** and **dependable** housings to suit many needs, from recreational diving to treasure hunting, marine research and Hollywood productions to U.S. Navy programs.

You see, at Gates, your selection of our product is only the beginning. We are here to service you, the customer, for as long as you own our product. Our Customer Service is second to none. We'll make every reasonable effort to support you wherever your adventures land you, including remote corners of the globe. Anytime you need advice, parts, overhaul, or repair, Gates will take care of you promptly and to your satisfaction.

Please read through all the documentation contained in this package to become familiar with your Gates housing **before** diving. It contains important and valuable information to make using your new housing easy to learn and use. Soon you'll be capturing images and showing your friends and colleagues the splendor of the undersea realm.

Complete and return the warranty card enclosed in this package to activate your *2-year renewable warranty*. You'll receive 2 years of warranty coverage for your investment and unprecedented peace of mind, only from Gates.

Gates wishes you the greatest success in your diving adventures. May you capture the memories of a lifetime and the envy of your friends. And remember.....
Don't take a chance...Take a **Gates!**

Sincerely,

John Ellerbrock
President and General Manager

Congratulations on owning a new *Gates housing!* You've selected a product that will provide years of value and reliable service. This housing was custom designed for the Sony *FX1/Z1* video camera for the underwater imaging professional. Please read through this entire guide to become familiar with the Gates *FX1/Z1* housing. The following setup guidelines will explain how to prepare and use your camera and housing so you'll get the best results from your video endeavors.

Before You Begin

Every Gates housing is pressure tested before leaving the factory to assure a watertight seal. As a precaution, however, ***it's a good idea to first setup and dive the housing without your Sony camera inside.*** Rough or abusive handling during shipment could have caused unnoticed damage after leaving the factory. In addition, you can get a good feel for the use of an underwater housing without worrying about getting a good shot. You can simply concentrate on the technique of holding a camera in position while fine tuning your buoyancy.

Camera and Housing Setup

After removing the housing from its shipping container or Gates Pak, carefully inspect for any damage that may have occurred during shipment. If you discover any, contact Gates or your dealer immediately for assistance.

Preparing the Sony FX1/Z1 Camera

Your Sony camera will need some preparation before placement into the housing.

1. **Remove any lens hood, cap or filters** from the lens.
2. **Display information.** The FX1/Z1 camera must be set to display information through the external monitor. This is done by entering the menu of the camera and selecting as follows: ***MENU> OTHER> DISPLAY OUTPUT> V-OUT/PANEL.*** If this does not work, you may need to press the RESET button (see camera manual for more on the RESET button) and then follow the above steps again.
3. **Remove the handstrap and the eye piece** from the electronic viewfinder on the camera. To remove the eye piece, push the release button and slide the eye piece up.



**Remove the handstrap
and the eye piece on the
viewfinder**

4. **Install manual focus gear** onto the focus ring of the camera lens. Place the focus gear over the front of the lens and slide it onto the focus ring with the gear teeth away from the front lens (see photo). It may be a snug fit. **Also note the alignment of the gear over the manual focus ring** on the lens as shown in the photo.



5. **Buoyancy Adjustment** Your FX1/Z1 housing is designed to be balanced and slightly negative underwater *in its basic configuration* -- which is the housing and a Standard or Flat Port. To achieve this there are 4 trim weights located inside the housing-- 1 in the back, 3 in the front -- which are positioned for proper buoyancy and balance. With the addition of accessory items, such as lights, batteries, external monitor, etc. the buoyancy and balance will naturally change, and most likely to the negative. The weights can be repositioned to other areas inside (and outside) the housing to reestablish trim. Extra mounting strips are provided with your housing for this purpose. However, **it is important when installing the weights in the housing that you make sure the weights do not interfere with the controls or camera placement.**

To remove a trim weight simply pull it away from the wall to which it is mounted. Start at one corner as this will help separate the locking strips. When securing them back into the housing you will feel a 'snap' as the locking strips engage.

If you wish to have finer buoyancy and balance adjustment, contact Gates for smaller trim weights.

⚡ Caution: *Remove weights for travel and shipping to avoid internal damage should the weights become dislodged from the self-sticking velcro during transport.*

6. **Install a tape** and charged battery.

Preparing the Housing

1. **Release the latches.** Three stainless steel safety latches secure the housing halves. ***They have a positive locking feature***, so to open them you must first depress the center bar release while lifting the rear lever. Depress the bar and lift the rear lever on the top latch, then undo it from its catch hook. Remove the two side latches in a similar fashion.
2. **Open the housing.** Separate the rear half of housing from the front.
3. **Remove the camera mount plate** from the housing. The plate is held in place by two small thumbscrews underneath. Loosen but do not remove the thumbscrews.
4. **Mate the camera to the mount plate.** Turn the camera over, mate the camera mount plate by aligning the hole in the center with the tripod mount on the camera.
5. **Secure the camera** to the camera mount plate with the small pan head screw with a coin or screwdriver. Tighten snug but do not over tighten.

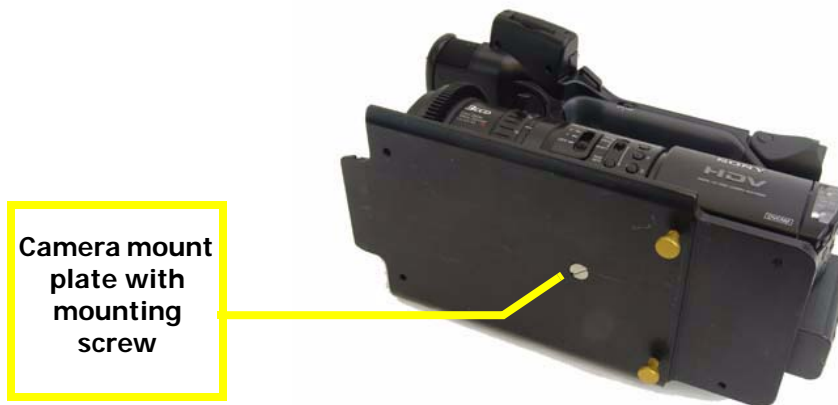

Installing the Sony camera.

1. **Pull out all controls** as far as they will go on the left side of the housing (Controls will be discussed in greater detail in a subsequent section).
2. **If you will be using an external monitor, plug in the external monitor cable** at this time. Locate the external monitor cable and plug it into the Audio/Video jack on the front right side of the camera. Turn the video plug downward before sliding the camera and mount plate into the housing to prevent interference with the zoom control.

Note: A subsequent section of this guide details mounting and use of the External Monitor.



Plug in the external monitor cable.

3. **Insert the camera.** Carefully slide the camera on its mount plate into the housing. It will stop when fully inserted.

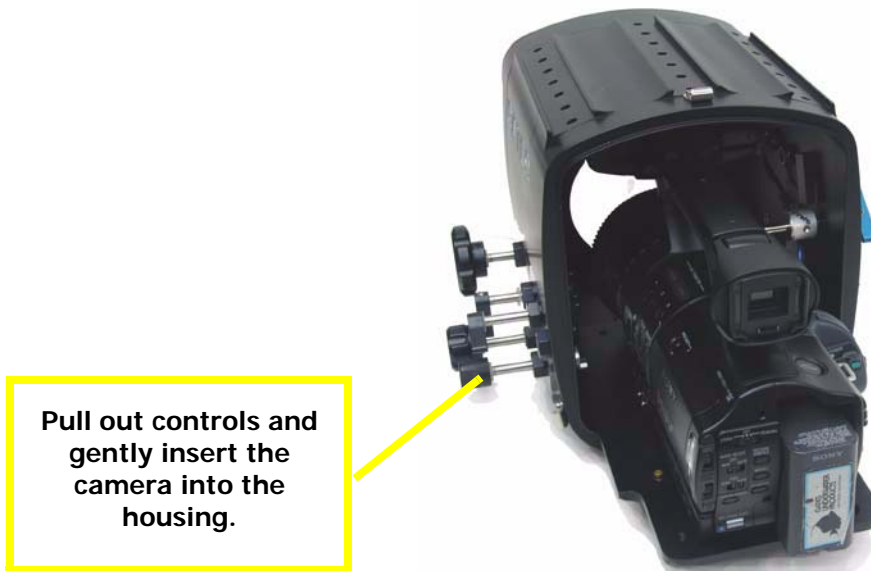

Pull out controls and gently insert the camera into the housing.

4. **If you intend to use the manual functions** of the camera, be sure **the Auto/Manual button** on the lower left side of the camera **is in the mid position**, not in the Auto Lock or Hold positions.

5. **Secure the camera.** Underneath the mount plate, use the two gold thumbscrews to secure the camera mount plate to the housing. Tighten until snug.



6. **Check controls.** When the camera is installed into the housing front press in each control and confirm proper operation (refer to the next section for more detail on controls).
✦ **Tip:** With the camera installed you can now get a good view inside the front half of the housing and most controls. Use a flashlight if necessary to become familiar with the operation and 'feel' of each control in their proper position prior to closing the housing.
7. **Tilt the camera viewfinder** for proper alignment with the viewfinder on the housing. Tip the camera viewfinder to approximately 10:00. In this position, the front edge line of the camera viewfinder will parallel the downward slope of the camera handle (see photo).



Closing the housing

1. **Carefully inspect** the orange o-ring on the back and the sealing surface on the front. Make sure they are clean and free of debris or marks that could compromise the seal.
2. **Mate the two halves of the housing.** Place the housing back onto housing front leading with the right side first to align the Camera/Off and Rec/Stby controls with the camera. Use the 'drip lip' to guide the alignment. The housing halves should mate easily with no obstructions. If there are any obstructions, separate the halves and identify the problem before trying again.



**Lead with the right side
to align the controls
with the camera.**

3. **Be sure the Shutter Speed/WB Mode control is pulled out** on the left side of the housing so you do not switch the Auto/Manual switch to Auto Lock or Hold positions if you intend to use all the manual functions on the camera.
4. **Align all three latches** -- Each latch should fall over the catch on the front of the housing. Close the two side latches at the same time, close the latch on top of housing last. Each latch will 'snap' and lock into position when closed.

**Mate the housing
halves, ensure proper
alignment and secure
latches.**



5. **Position controls for mating** by pushing them inward and aligning the control heads with the camera. With the camera turned on, ensure that you have proper alignment of each control with the camera buttons.

⚡ **Caution:** The safety latches must be *closed* and *locked* prior to use to avoid opening underwater. *It is your responsibility to make sure the latches are secure and locked, and in good condition. DO NOT enter the water with a faulty latch. Gates will replace a damaged or faulty latch free of charge.*

6. **Carefully inspect** parting line between front and rear. If this line is not even and free of gaps all the way around, remove back and find the reason why. (O-ring out of place, hand strap interference, etc.) ***FAILURE TO DO THIS MAY RESULT IN A WET CAMERA!***

⚡ **Tip:** A simple test of the main seal is to try and slip a piece of paper past the o-ring. A properly sealed housing will have no gaps through which the paper can pass.

7. **Check the Port.** It should be seated flush on the front bulkhead and no uneven gaps should exist. If a gap is found, remove the port and re-install per directions in the 'Port' section on page 13 of this guide.

8. **Power up camera and check all controls.** Check all controls for the proper operation before entering water. The following section describes each control in detail for proper operation.

⚡ **Caution:** **It is important to keep the viewfinder cap on the housing viewfinder above water to protect the camera from direct sunlight damage.**

Controls

General Information

Your Gates housing utilizes 100% mechanical controls to provide you the most reliable operation possible. They are all rotational in nature: that is, there are no push buttons that can become sticky or depress under pressure. There are no batteries to change and little maintenance to perform.

The housing controls are designed by Gates engineers, to the extent possible, to feel and behave like the camera controls. You can also verify operation on nearly every function on the external monitor. With time and use, the housing controls will become quite familiar and you'll find operating them requires similar skill as the actual camera controls.

To help acquaint you with the housing controls, Gates recommends reviewing each control individually, how it actuates the corresponding camera control, and actually operating it to get a 'feel' for the control. You can view all front housing controls with the housing open. After reviewing all controls, perform a 'simulated' dive by operating the controls as you would in the water.

One final note about controls: when operating any control out of water, ***you may need to press the control against the housing, into the position it would naturally find while under water pressure.*** The controls will operate properly in this position.

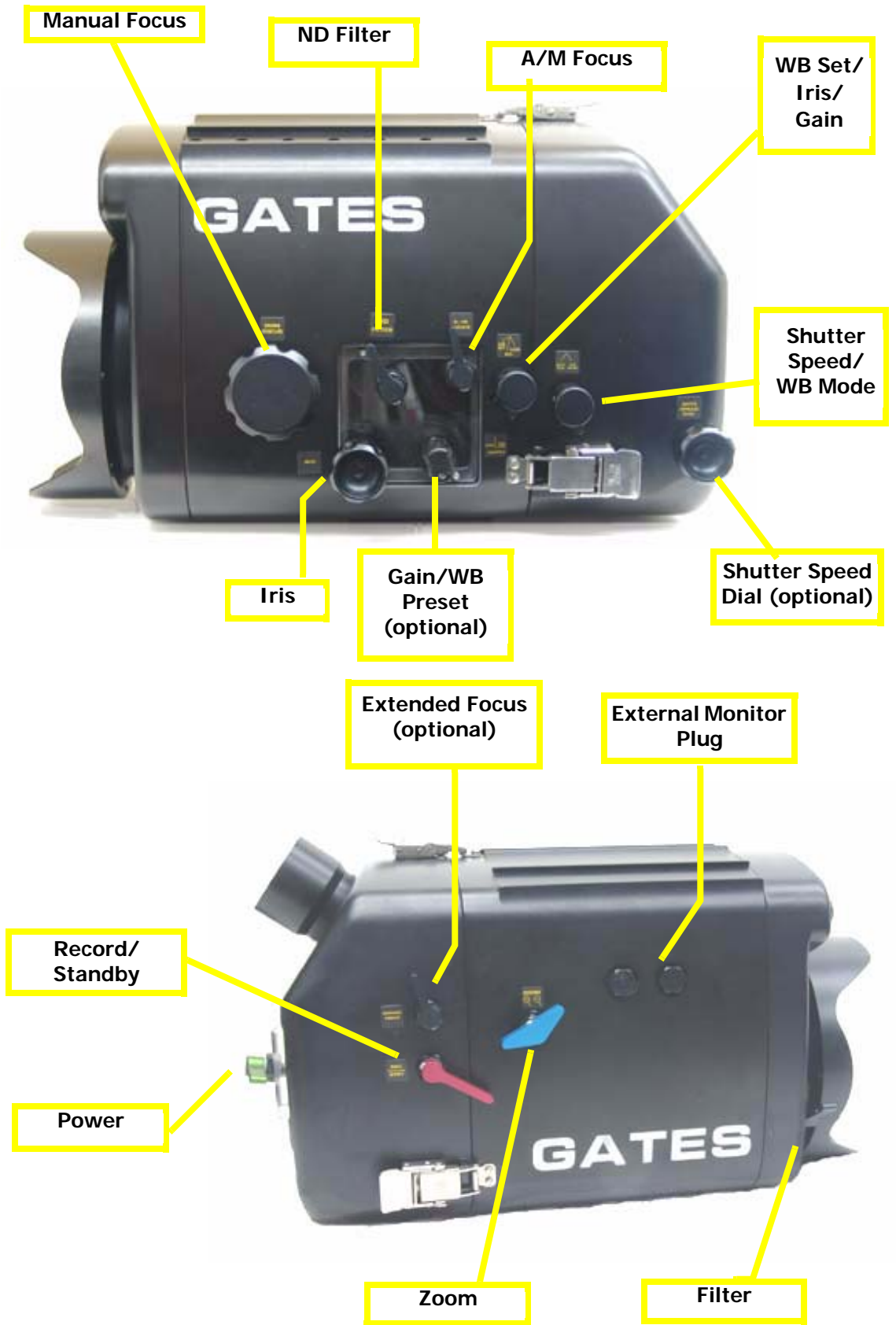

Control Operation

- **Power (Camera/Off)** This control is easily identified by the **green** color. The positions for this control are exactly like that found on the camera switch, and you will 'feel' the switch move into each position as it passes the tactile detentes. The mode selected will display in the monitor for verification. In the "Off" position the trigger will point to the right.
- **Record/Standby** The Record Standby control is **red** and operates by a short motion counter-clockwise on the lever trigger. Press once to Record; press again for Standby. You will "feel" the record/standby button on the camera actuate through the control as it is depressed.
- **Zoom** The Zoom control is **blue** for quick identification. It operates with a simple rotational movement of the lever trigger. Note that the zoom is variable – that is, the further you move the control, the faster the camera will zoom from wide to telephoto and vice-versa.
- **Neutral Density (ND) Filter** The ND Filter Control rotates to move through the 3 ND settings: ND Off, ND1, and ND2.
- **Auto/Manual (A/M) Focus** The A/M Focus control toggles the camera between manual and auto focus modes. When in manual focus, the manual focus knob can be used to focus on subjects.
- **Manual Focus Knob** The Manual Focus Knob is located on the left side in front of the side window, and provides fine control of focus. The A/M focus control must be used to set the camera into manual focus mode to utilize this control.
- **Filter Control** Rotate this control to move the color correction filter in and out of position in front of the camera lens. It will stop when centered over the lens.

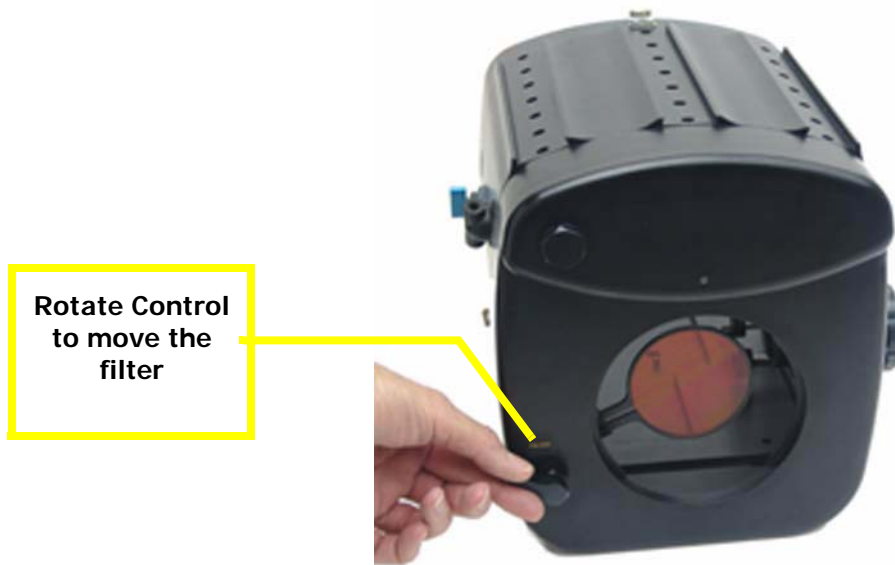

- **Shutter Speed/White Balance Mode** This control depresses the buttons by aligning the pointer on the control knob with the indents beneath the knob.

To adjust shutter speed, depress the button to display current value then rotate the optional shutter speed dial knob.

To adjust white balance, depress the white balance mode control and then depress the White Balance Set control to set. If you have the optional White Balance Preset Control, depress the White Balance Mode, select A, B or preset, then depress the White Balance Set control. The control will not push in if the pointer on the knob is not aligned with the indents.

- **Shutter Speed Dial (if installed)** rotates to adjust shutter speed.
- **Gain/White Balance Preset Switch (if installed)** This control performs two functions. Rotation of the knob will adjust gain or white balance presets.

With the knob pulled out, position the dot forward then push control in to mate the control head with the **Gain switch**.

With the knob pulled out, position the dot towards the back of the housing then push the control in to mate the control head with the **White Balance Preset switch**.

Rotate this control head away from the indents when diving to prevent unintended activation of the camera functions.

- **White Balance Set/Iris/Gain** This control depresses the buttons by aligning the pointer on the control knob with the indents beneath the knob to set white balance, display current aperture value or display current gain value. When aligned, push in the control to actuate the buttons. The knob will not push in if the pointer on the knob is not aligned with the indents.

Rotate this control head away from the indents when diving to prevent unintended activation of the camera functions.

- **Iris** To display the current aperture, use the WB Set/Iris/Gain control to press Iris. The iris, or aperture, is changed by rotating the Iris control knob.
- **Expanded Focus (if installed)** expands the image, for 4 seconds, **in the viewfinder only** for fine tuning of manual focus. You will not be able to see this on an external monitor.

Attaching the Handles

1. **Remove the knurled brass retainer** from the handles, then place the handles just behind the dovetail found on the bottom of the housing (see photo).
2. **Slide the handles** forward onto the housing dovetail. It may take firm pressure to fully seat the handles until they come to a solid stop.
3. **Attach the knurled retainer** to secure the handles onto the housing.

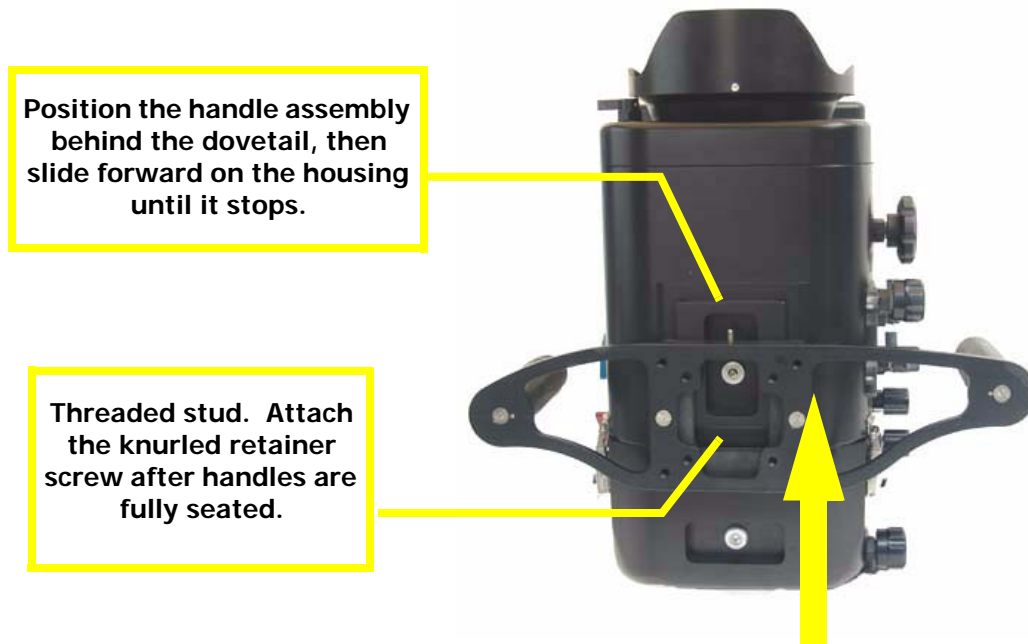

Ports

Change

The ports for the *FX1/Z1* housing are attached with a bayonet-style mount. Port changes are easy and straightforward:

1. **To remove a port:**
 - Rotate the port 90 degrees counter-clockwise until it stops. The alignment dots will be 90 degrees apart from each other.
 - Pull the port away from the housing.
 - If you have trouble, look inside the front half of the housing and ensure the bayonet tabs of the port are lined up with the cut-outs of the port opening.
- ✍ **Tip:** If the port has been on the housing for an extended period of time, it may be difficult to turn. You may find that a strap wrench helps to remove it.

2. **Inspect the o-ring** -- Before installing a port, perform an inspection and lubrication of the **sealing o-ring**. The **buffer o-ring** is a cushion between the housing and the port and does not require lubrication. See "O-ring Care and Maintenance" in this Use and Care Guide for specific details.

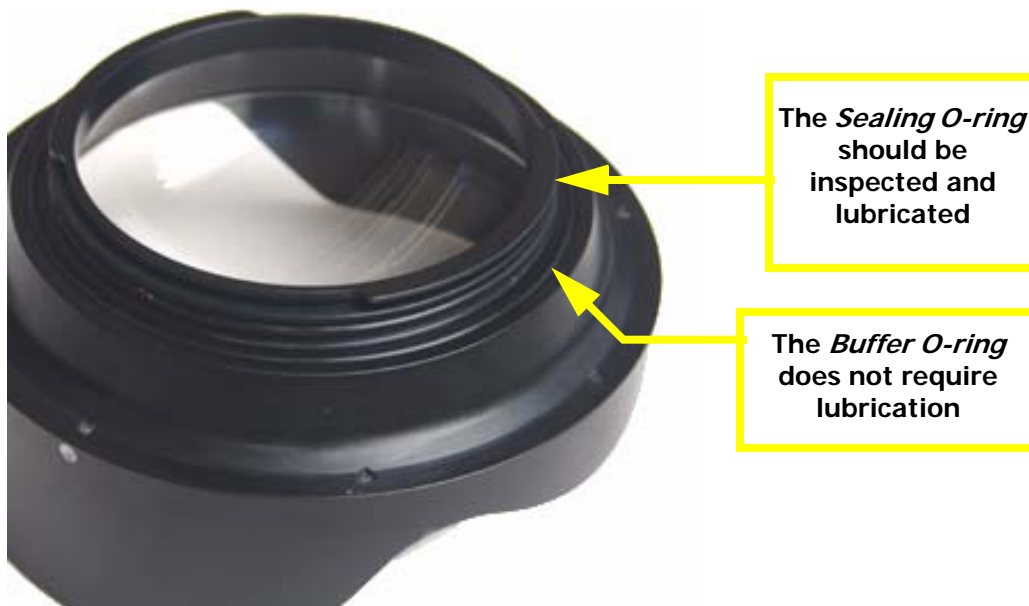

3. **Insert the port** with the bayonets on the port aligned with the cut-outs of the port opening on the inside of the front bulkhead. Press the port onto the housing until it is flush with the front bulkhead. Then turn the port 90 degrees clockwise so the silver dot on the port is aligned with the silver dot on the front of the housing above the port. The port has a built in stop to prevent further rotation.

✘ **Caution:** Perform a final check after installing a port to ensure it's flush with the front bulkhead of the housing. If not, remove the port and reinstall. Failure to do so may result in flooding.



Use of Diopters

- The FP44 Flat Port is designed specifically for macro video using multiple diopters mounted to the camera lens. Swing the color correction filter up, you will need not be able to use it with diopters on the camera.

Use of the Color Correction Filter

- The internal color correction filter is specially designed by UR Pro to correct for color loss underwater. A "blue water" version (orange in color) is provided standard with the FX1/Z1 housing, however a "green water" version (pink in color) is available as an option.
- **Changing the filter** is accomplished by loosening the screw on the filter holder closest to the filter element using a 7/64" allen wrench. Push element into the housing while stabilizing the filter holder. Reverse this process to install new filter element.
- You will need to **remove the filter holder when using a non-Gates wide angle lens** mounted directly on your camera. To do so, remove the screw holding the filter holder to the filter mount block using a 7/64" allen wrench. The mount block remains attached to the control shaft.

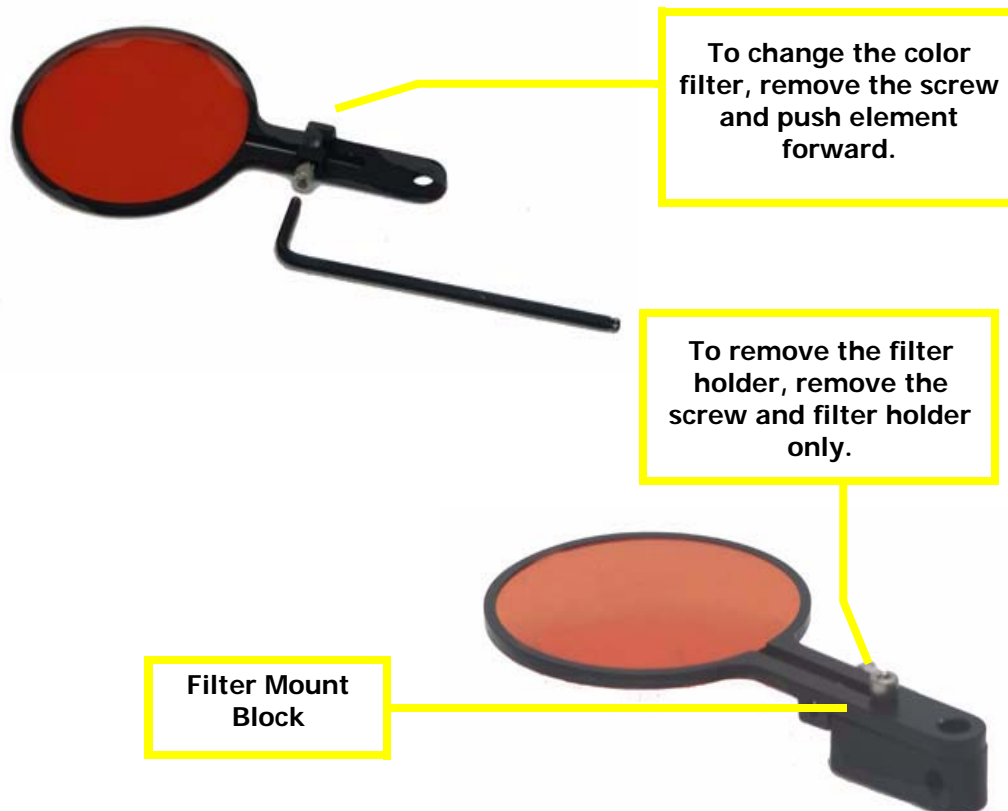

Cleaning Ports

Gates ports can be cleaned readily by following these simple guidelines.

- **Dust or Lint** can be blown with compressed air, preferably air from a can. **Do not clean the surfaces if it is unnecessary.**
- **Salt deposits or sand** may also be removed with compressed air. Use a soft lens brush if necessary to brush away foreign material that remains.
- **If necessary, rinse fresh water** over the outside of the port to loosen any residual salt or sand that may remain. Do this with the **port sealed** on your housing to keep water away from the rear of the port.
- **Only if necessary, clean the port** using a mild glass cleaning solution and a non-abrasive, lint free cloth. **Use light circular strokes** when wiping away cleaning solution and any foreign material. Excessive pressure used when cleaning dirty lenses (*e.g.*, rubbing sand into the lens surfaces) may damage coatings. **Use a light touch.**

⚡ Caution: Not all cloths are lint free and non-abrasive! Use of an abrasive material (such as cotton balls and cotton fabric) may scratch the glass and/or coating of Gates ports, and will void the warranty.

⚡ Tip: Gates offers approved cleaning solutions and lint free cloths as accessory items. Use of these materials will not void your warranty.

Optional External Monitor

This section covers mounting of the optional monitor to the *FX1/Z1* housing and connection to the Sony camera. Note that the monitor has no controls; it will power up automatically when a video signal is present, it senses a PAL or NTSC signal automatically and displays a proper image regardless of video format.

The EM253 offers a 2.5"/64.26mm color active LCD and the EM419 offers a 4.1"/104mm color active LCD.



Camera Connection and Setup

1. **Connect to the Sony Camera** by plugging in the video cable located inside the housing. The video cable will plug into the Audio/Video jack on the front right side of the camera, turn the plug downward before sliding the camera and mount plate into the housing.

You can verify operation at this time by plugging in the monitor (see below) and turning on the camera. Note – your Sony camera must be set to display external video, as well as camera information. If you have not already set the external video mode, please refer to the "**Preparing the Camera**" section for directions.



2. **Attach the monitor bracket** to the swivel base on the small metal dovetail. (see photo). Remove the wing nut and bolt from the monitor swivel yoke, and then mate the swivel yoke and swivel base together far enough to re-insert the bolt. Tighten until the monitor moves, but with some resistance.

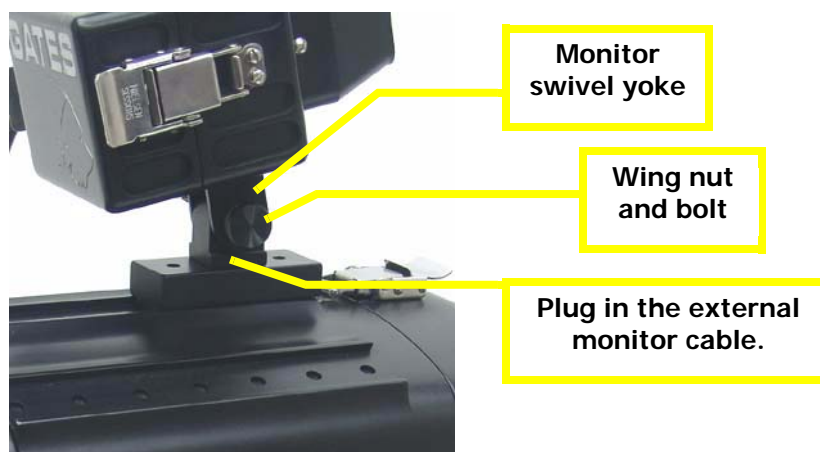

3. **Slide dovetail and monitor** into the grooves on top of the housing and tighten in place with nylon thumb screws.

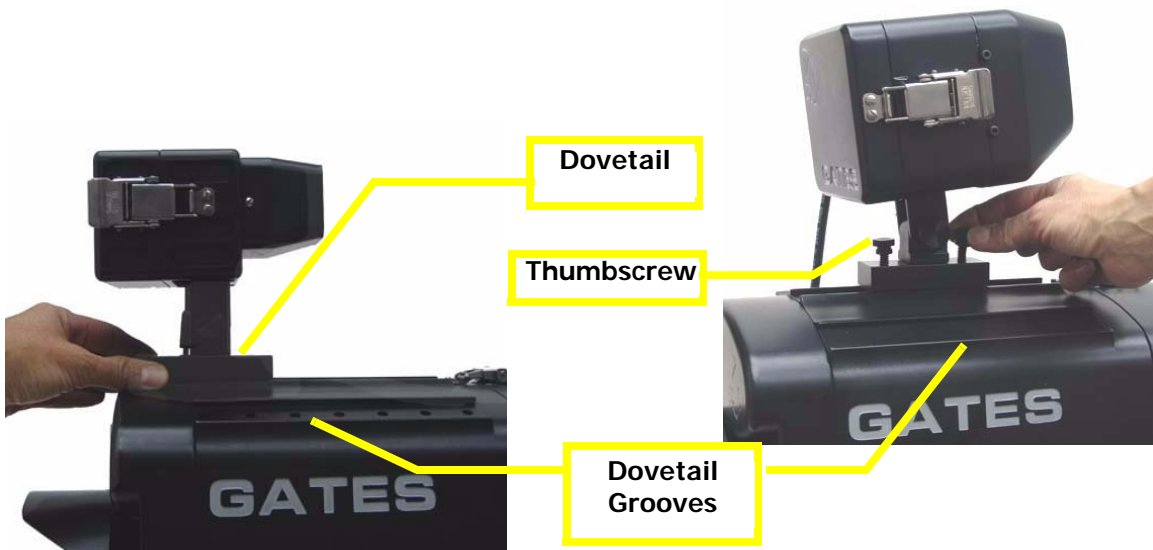

4. **Plug in the monitor cable** to the *FX1/Z1* housing bulkhead connector, which is found on the right side of the housing. Mate the cable until fully seated into the bulkhead connector.

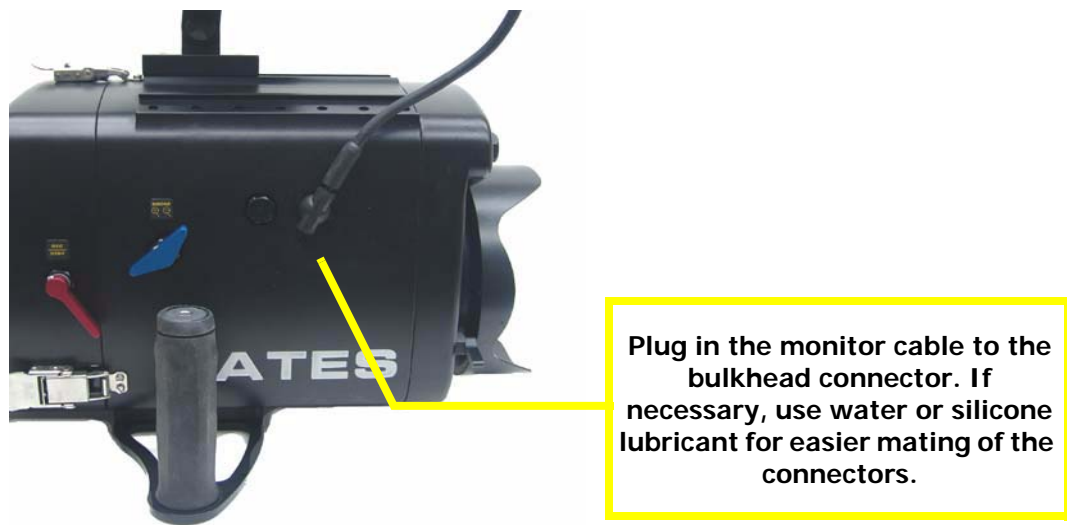

⚡ Caution: If you are not using the monitor for any reason, do not plug the RCA connector into the camera.

5. **Verify operation** by turning on the camera. If properly connected, the monitor will automatically turn on and display an image. You may have to wait 3-4 seconds before an image will appear.

Monitor Setup, Use and Care

The Monitor SU&C Guide is included as a separate document with your *FX1/Z1* Guide.

Housing Care and Maintenance

Proper care of your Gates housing is important to provide you reliable operation and long life. You'll find all the guidelines in the "Housing Care and Maintenance" pages of this document. You can also find it on Gates web site at www.gateshousings.com.

Optional Submersible Microphone

If you have the submersible microphone installed on your Gates housing, there are special considerations for setting up your camera and connections to capture external audio.

HDR-FX1:

1. The submersible microphone will plug directly into the external microphone jack on the camera.



2. enter the menu of the camera and select the following: ***MENU> AUDIO SET> MIC/LINE IN> EXT MIC*** to activate the external microphone connector for input.

HVR-Z1U:

1. The Z1 requires the use of the XLR audio adapter. Plug this into the Input 2 connector on the camera, then plug the submersible microphone into this adapter. Be sure to fully engage the connectors.

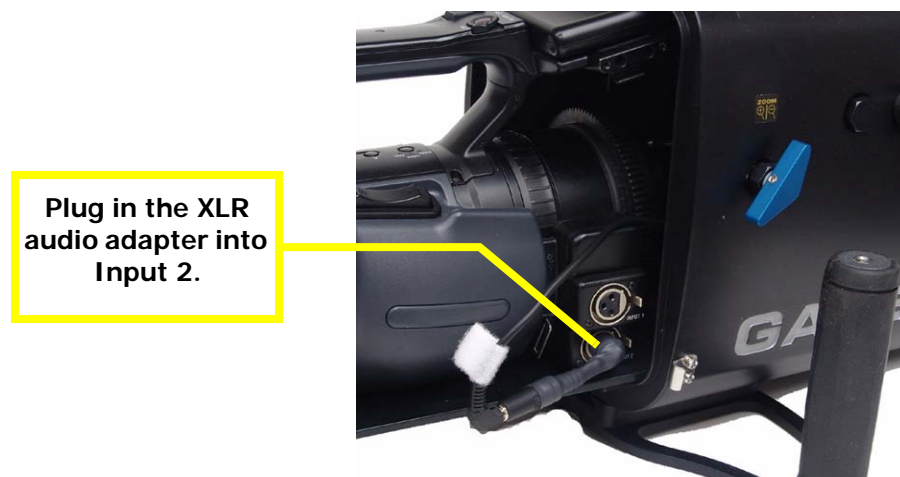

2. Next to the Input 2 connector is the PHANTOM power switch, this must be set to ON.



3. Enter the menu of the camera to AUDIO SET and set the following parameters:

AUDIO MON> CH1,CH2 to record audio to one track
AUDIO MON> CH2 to record audio to both tracks
LIMIT> OFF
NR> ON
MIC SELECT> XLR

XLR SET:

- **XLR CH SELECT> CH1**
- **INPUT 1 LEVEL> MIC**
- **INPUT 2 LEVEL> MIC**

4. The audio input levels should also be adjusted manually to setting 8 for best response. Further adjustment to the input level can be made to meet your individual audio needs.

Optional Water Alarm

If your Gates housing includes the optional water alarm, there are three alarm conditions to watch for:

Condition	LED (if installed)	Siren (always installed)
New Battery (when inserted)	Bright intense blink for 6 seconds	Screaming sound for 6 seconds
Flood	Bright intense blink	Screaming sound. Alarm will sound for duration of flood + 6 seconds.
Low Battery	Low intensity fast blink	Intermittent chirp for 40 seconds after flood condition.

You can test the alarm anytime by shorting the flood contacts that lead to the water alarm transducer. The flood condition will activate for 6 seconds. If the battery is low, the low battery condition will sound.

The battery in your housing is either a single 9V type or two 3V wafer cells, commonly referenced as CR2032. Gates recommends the battery be changed once a year.

O-ring Care and Maintenance

Your Gates housing for Sony *FX1/Z1* has 3 serviceable o-rings. One is located between the mating halves of the housing (the large orange one), and the other two are located on the rear of each Port.

Servicing the o-rings is easy, and is covered in the "O-Ring Care and Maintenance" document in this package. You can also find it on Gates web site at www.gateshousings.com.

⚡ Caution: Do not lubricate the large orange o-ring! It is a special silicone o-ring and can be damaged by petroleum-based lubricants.

⚡ Caution: *Never* use metal tools or objects for removing o-rings!

Customer Support

If you have any questions or require further assistance with your *FX1/Z1* housing, contact your dealer or Gates directly and we'll be happy to assist.

Email: Customersrvc@GatesHousings.com

Phone: 858-272-2501

Fax: 858-272-1208

